

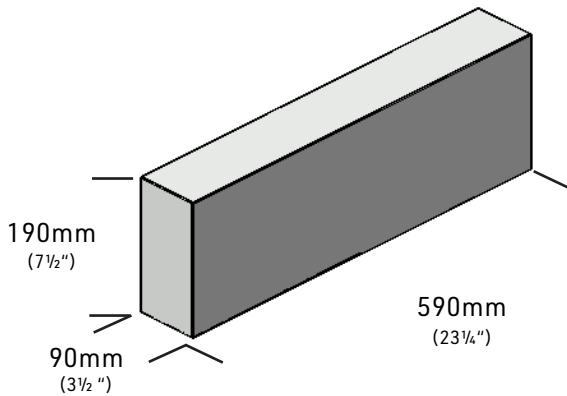

# TECHNICAL DETAILS

## 90x190x590 Tap Stretcher

### PRODUCT DRAWINGS



### PRODUCT DETAILS

	90x190x590 Tap Stretcher		90x190x590 Tap Corner	
	Metric	Imperial	Metric	Imperial
Selling UoM		EA		EA
Units/Skid	60EA	60EA	60EA	60EA
Weight/Each	21.5kg	47.39lbs	21.5kg	47.39lbs
Weight/Skid	1,311kg	2,883lbs	1,311kg	2,883lbs
# of Layers	3	3	3	3
Pieces/Layer	20	20	20	20
Coverage/Unit	0.124m <sup>2</sup>	1.33sf	0.124m <sup>2</sup>	1.33sf
Coverage/Skid	7.41m <sup>2</sup>	79.8sf	7.41m <sup>2</sup>	79.8sf
Linear Unit/Piece	0.20m	0.66sf	0.20m	0.66lf
Pallet Size	101cmx119cm	40"x47"	101cmx119cm	40"x47"

## CORNERS

Corner units are sold separately.

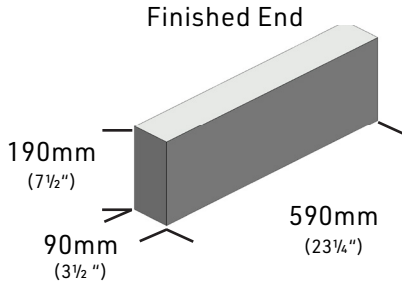

## TYPICAL INSTALLATION PATTERN

Running Bond

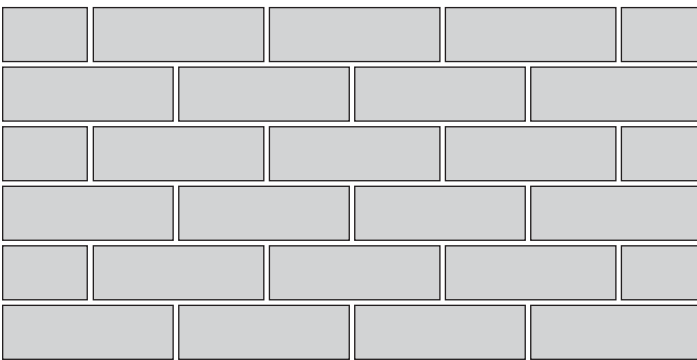

Stack Bond

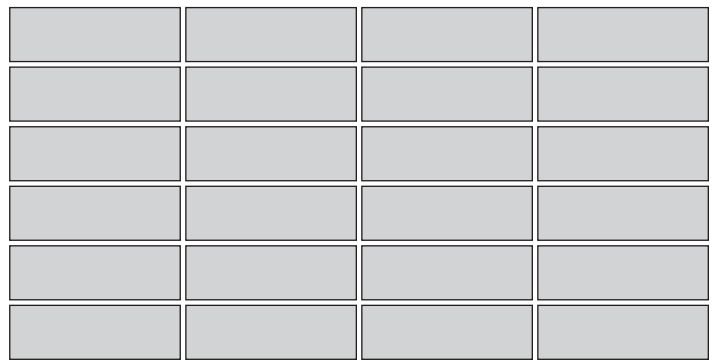

Typical Installation Guidelines: • Blend product from multiple packages for most natural look

## TYPICAL MORTAR JOINT

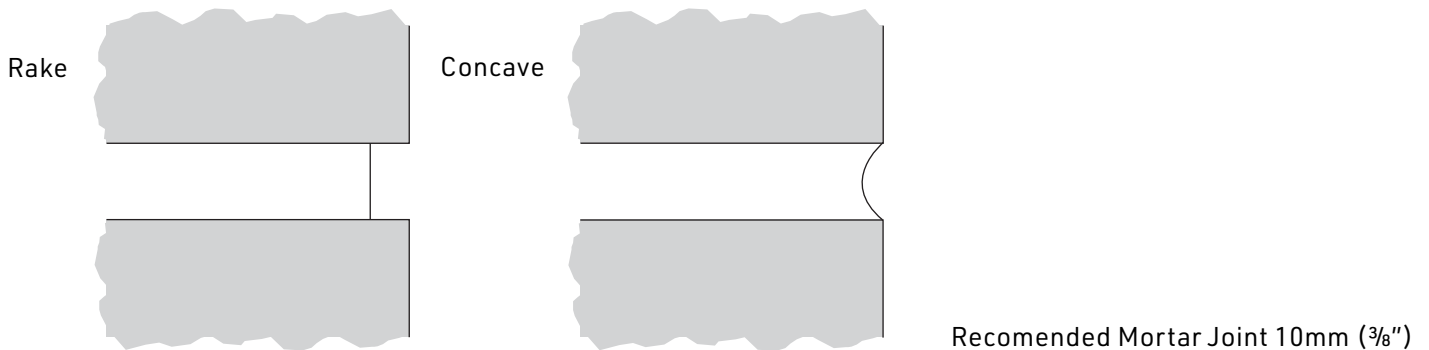

## PRODUCT OPTIONS

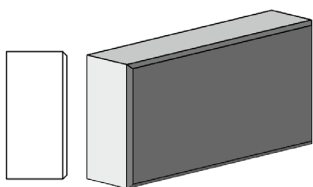

Bevel  
10mm  
(3/8")

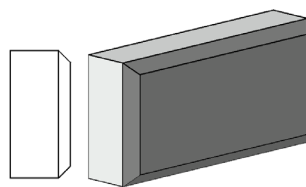

Bevel  
25mm  
(1")

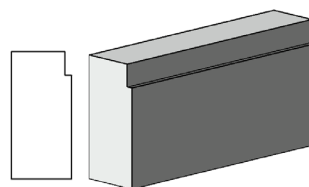

Margin Cut  
10mm x 35mm  
(3/8" x 1 3/8")

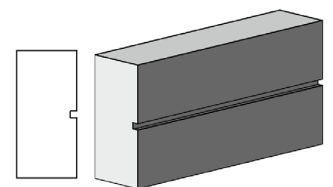

Horizontal Score  
10mm x 10mm  
(3/8" x 3/8")

## TYPICAL COURSING GUIDE

Tables Include one unit and one joint.

Vertical Units	10mm Joint	3/8" Joint	Horizontal Units	10mm Joint	3/8" Joint
1	200mm	77/8"	1	600mm	235/8"
2	400mm	153/4"	2	1,200mm	471/4"
3	600mm	235/8"	3	1,800mm	703/4"
4	800mm	311/2"	4	2,400mm	943/8"
5	1,000mm	393/8"	5	3,000mm	118"
6	1,200mm	471/4"	6	3,600mm	1415/8"
7	1,400mm	551/8"	7	4,200mm	1651/4"
8	1,600mm	63"	8	4,800mm	1887/8"
9	1,800mm	707/8"	9	5,400mm	2123/8"
10	2,000mm	783/4"	10	6,000mm	236"
20	4,000mm	1571/2"	20	12,000mm	472"
30	6,000mm	2361/4"	30	18,000mm	7081/8"
40	8,000mm	315"	40	24,000mm	9441/8"
50	10,000mm	3933/4"	50	30,000mm	1,1801/8"
100	20,000mm	7871/2"	100	60,000mm	2,3603/8"

## CODES & STANDARDS

Shouldice Stone Products are supported by the following National Codes & Standards. Refer to local building codes and standards to confirm best practice.

### CANADIAN

[CSA A165 Standards on Concrete Masonry Units](#)

[CSA A371 Masonry Construction for Buildings](#)

[CSA A179 Mortar and Grout for Unit Masonry](#)

[CSA A370 Connectors for Masonry](#)

### AMERICAN

[ASTM C55 Specification for Concrete Building Brick](#)

[ASTM C90 Specification for Loadbearing Concrete Masonry Units](#)

[ASTM C270 Specification for Mortar for Unit Masonry](#)

[ASTM C476 Specification for Grout for Masonry](#)

[ASTM C1634 Specification for Concrete Facing Brick and Other Concrete Masonry Facing Units](#)

[NCMA TEK 8-4A Cleaning Concrete Masonry](#)

[NCMA TEK 9-1A Mortars for Concrete Masonry](#)

[NCMA TEK 8-3A Control and Removal of Efflorescence](#)

[NCMA TEK 10-4 Crack Control for Concrete Brick and other Concrete Masonry Veneers](#)

[NCMA TEK 19-5A Flashing Details for Concrete Masonry Walls](#)

## TYPICAL UNIT PROPERTIES

Products exceed the CSA and ASTM standards.

	Standard	Compression Strength	Absorption	Density	Fire Rate (Hours)
CSA	A165.1	>15mpa	<8%	>2000kg/m <sup>2</sup>	1.4
ASTM	C1634	>3000psi	<12lb/ft <sup>3</sup>	>125lb/ft <sup>3</sup>	

## HATCH PATTERNS & TEXTURE MAPS

To access Shouldice Stone Hatch Patterns and texture maps visit the corresponding [shouldice.ca](https://www.shouldice.ca) [product page](#) for current availability.

## CONTACT US

For technical questions regarding our product line please contact our knowledgeable customer service team. By phone: **800.265.3174** or email: **designer@shouldice.ca**